

# SAMSON METALS Ltd.

(Imperial - L.S.D. S136-07)

## SM900W

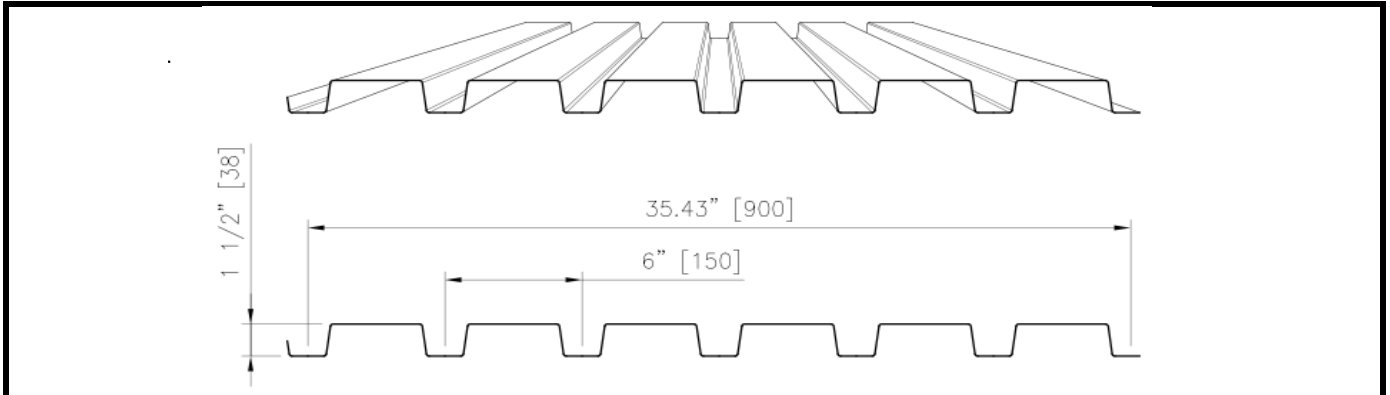

### Properties for SM900W ( Per foot width )

Gauge Number	Base Steel Minimum Thickness Inches	Weight Pounds per Sq Ft.	MID - SPAN						SUPPORT						Coeff. of Defect. L / 180	Allowable Bear'g 1.5" K / ft.		Allowable Shear Ov*Vn K/Ft
			Section Modulus		Coeff. of Stress Csm	Moment of Inertia		Section Modulus		Coeff. of Stress C <sub>ss</sub>	Moment of Inertia		EXT	INT				
			Sm	In3		Im	In4	Sm	In3		Im	In4						
24	0.024	1.328	0.1334			0.1179	0.1334			0.1330				0.50	0.75	1.994		
22	0.030	1.660	0.1786			0.1567	0.1786			0.1567				0.75	1.15	2.493		
20	0.036	1.992	0.2178			0.1954	0.2178			0.1957				1.05	1.64	2.991		

### Allowable Superimposed Load Tables - psf

Span Ft.	ONE SPAN								TWO EQUAL SPANS								THREE EQUAL SPANS							
	0.024		0.030		0.036				0.024		0.030		0.036				0.024		0.030		0.036			
	A	B	A	B	A	B	A	B	A	B	A	B	A	B	A	B	A	B	A	B	A	B	A	B
4.0	110	*	147	*	180	*			94	*	144	*	189	*			107	*	164	*	232	*		
4.5	87	*	116	*	142	*			84	*	118	*	149	*			95	*	146	*	187	*		
5.0	70	*	94	*	115	*			71	*	96	*	121	*			85	*	120	*	151	*		
5.5	58	*	78	*	95	*			59	*	79	*	100	*			74	*	99	*	125	*		
6.0	49	48	65	63	80	79			50	*	67	*	84	*			62	*	83	*	195	*		
6.5	42	37	56	50	68	62			42	*	57	*	72	*			53	*	71	*	89	*		
7.0	36	30	48	40	59	50			36	*	49	*	62	*			46	*	61	*	77	*		
7.5	31	24	42	32	51	40			32	*	43	*	54	*			40	*	53	*	67	*		
8.0	28	20	37	27	45	33			28	*	37	*	47	*			35	*	47	*	59	*		
8.5	24	17	33	22	40	28			25	*	33	*	42	*			31	*	41	*	52	*		
9.0	22	14	29	19	35	23			22	*	30	*	37	*			28	27	37	35	47	44		
9.5	20	12	26	16	32	20			20	29	27	38	33	38			25	23	33	30	42	38		

#### SM900W Load Table Notes

- 1) Column 'A' - Loads based on stress. Column 'B' - Loads based on L / 180 deflection. ( \* ) denotes stress governs.
- 2) Table lists lower value of bending or bearing resistance. **Italic** denotes web crippling governs.
- 3) For deflection loads other than L / 240 multiply column 'B' by the following factors:

DEFLECTION	MULTIPLIER
L / 240	0.75
L / 360	0.5

- 3) Load tables based on use of A653 Structural Quality Steel Sheet Grade 33 (maximum stress 29.7 Ksi).
- 4) Sum of specified roof live load & roofing weights to be equal or less allowable superimposed loads above.
- 5) Contact your **SAMSON METALS** representative for more information.